

## TECHNICAL DATA SHEET STAINLESS STEEL CLADDING

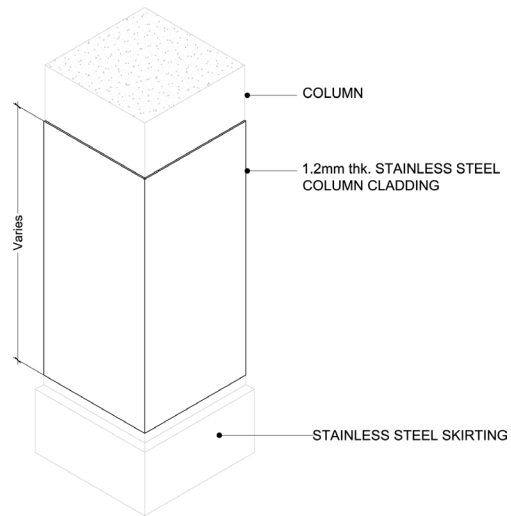

A1C's stainless steel cladding is ideal for protecting your columns. With either brushed or polished finish this cladding will turn any environment into a sleek and sophisticated area. Custom designed and fitted for any requirement.

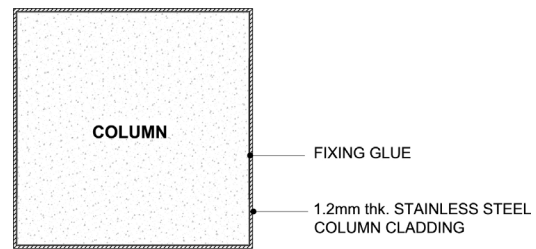

### FEATURES

- High Quality
- Custom Fitted
- Seamless Joins
- Cut to Length

	LENGTH	WIDTH	THICKNESS	MATERIAL	FIXING	FINISH
<b>STAINLESS STEEL CLADDING</b>						
	Custom	Custom	1.2 mm & Custom	SS304 SS316 SS316L	Screw Adhesive	SS Brushed SS Polished

### ACCESS 1 CONTROLS - UAE

European Business Centre PO Box 473549  
Dubai Investment Park 1, Dubai UAE  
T: +971 (0) 4 813 5212 | F: +971 (0) 4 813 5213  
E: sales@access1c.com | W: www.access1c.com

### ACCESS 1 COMPANY - AUSTRALIA

7 Lucknow Crescent  
Thomastown Victoria, Australia  
T: +61 (03) 9469 3600 | F: +61 (03) 9469 3622  
E: sales@accessone.com.au | W: www.accessone.com.au